

VIADRUS

Power of heating

Hercules DUO

Automatic cast-iron solid fuel boiler

The main advantage of this boiler is all cast iron boiler block with extremely long service life and easy access for cleaning thanks to two big cleaning doors. Retort burner installed in the base of boiler is used for burning coal or pellets. Fuel is supplied to the burner with the screw feeder having advanced protection against fuel reservoir fire penetration. The boilers designed for open heating systems needn't to be equipped with the overheating security device. It is necessary to specify just the size of fuel reservoir when ordering the boiler. Its position can be selected during boiler installation.

Advantages:

- Class 3 according to EN 303-5
- long service life of cast iron boiler block
- high fuel variability
- HMI display and control unit
- easy control thanks to text menu
- room thermostat compatible
- two sizes of fuel reservoir
- universal left/right position fuel reservoir

Fuel - automatic mode / fuel humidity:

- hard coal, 10~18 mm / <12%
- soft coal, 10~25 mm / <20%
- wooden pellets, Ø 6~8 mm / <12%

Boiler output - automatic mode:

- 6,0~35,0 kW



Technical parameters

Section number	pcs	4	5	6	7	
Boiler class according to EN 303 - 5	-			3		
Rated output	kW	20	25	30	35	
Adjustable output	kW	6,0~20,0	7,5~25,0	9,0~30,0	10,5~35,0	
Fuel consumption	- soft coal	kg/hour	1,4~4,5	1,7~5,6	2,0~6,7	2,3~7,7
	- hard coal	kg/hour	1,0~3,4	1,3~4,2	1,5~5,0	1,8~5,8
	- wooden pellets	kg/hour	1,5~4,9	1,8~6,1	2,2~7,3	2,6~8,5
Fuel consumption in stand-by mode - soft coal / hard coal / wooden pellets	kg/hour		0,10 / 0,13 / 0,35			
Efficiency	- soft coal	%	<83,1	<85,0	<87,0	<89,0
	- hard coal	%	<84,2	<85,0	<86,0	<87,0
	- wooden pellets	%	<87,3	<87,4	<87,5	<87,5
Flue gases maximal temperature	- soft coal	°C	116~197	100~180	90~170	90~165
	- hard coal	°C	111~196	90~170	80~165	80~160
	- wooden pellets	°C	95~175	90~165	80~160	80~155
Fuel reservoir capacity small / big	l		269 / 528			
Burning time at rated output	- soft coal, small / big reservoir	hour	36:15 / 71:30	29:10 / 57:20	24:30 / 48:15	21:15 / 42:00
	- hard coal, small / big reservoir	hour	45:10 / 88:40	36:30 / 71:35	30:35 / 60:15	26:25 / 52:00
	- wooden pellets, small / big reservoir	hour	27:10 / 53:20	21:45 / 42:40	18:10 / 35:35	15:30 / 30:30
Total depth H	mm	760	870	980	1090	
Total width	- small / big reservoir	mm		1340 / 1990		
Total height including open reservoir door	mm			1940		
Weight	- small / big reservoir	kg	465 / 496	517 / 547	569 / 598	621 / 649
Chimney connection diameter	mm			156		
Chimney draught	Pa	15~20	15~20	20~25	20~25	
Heating and return water connection	-			2"		
Maximal water working / testing overpressure	kPa			250 / 500		
Recommended water working temperature	°C	50~85	65~85	65~85	65~85	
Minimum water inlet temperature	°C	45	50	50	50	
Water volume	l	60	72	84	96	
Noise level	dB			<65 dB (A)		
Connecting voltage	-			1/N/PE 230 V AC 50 Hz TN-S		
Maximal electric input	W			85		
Control box electric protection	-			IP44		

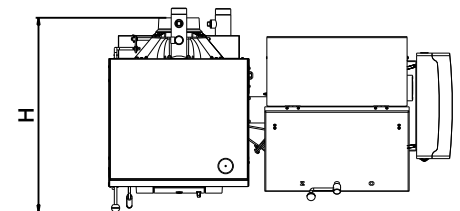
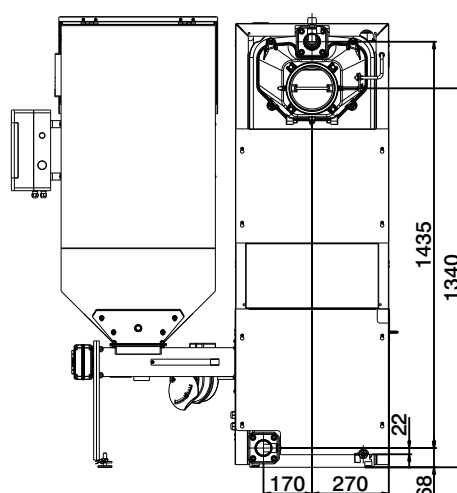
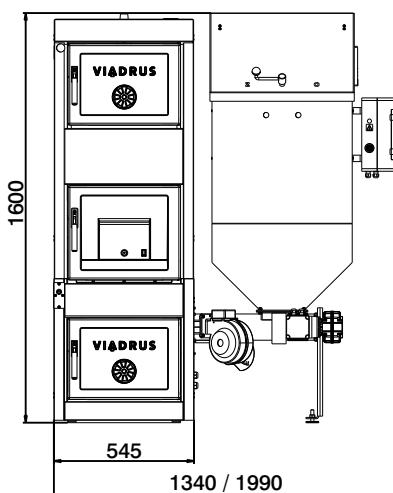

Your dealer